

LuLeey QSFP28 to SFP28 Adapter (QSA) Module

Features

- Trouble-free installation and network bring-up
- Compliant to industry standards: SFF-8665
- Compliant to industry standards: SFF-8432
- Precision process control for minimization of pair-to-pair skew
- 1 independent duplex channels operating at 25Gbps, also support for 10Gbps, 5Gbps data rates
- All-metal housing for superior EMI performance
- 100ohm differential impedance system
- Operating case temperature: -20 to 85°C
- Low insertion loss
- Low crosstalk
- Secure latching mechanism
- RoHS compliant
- Compatible with RoHS
- Single +3.3V power supply

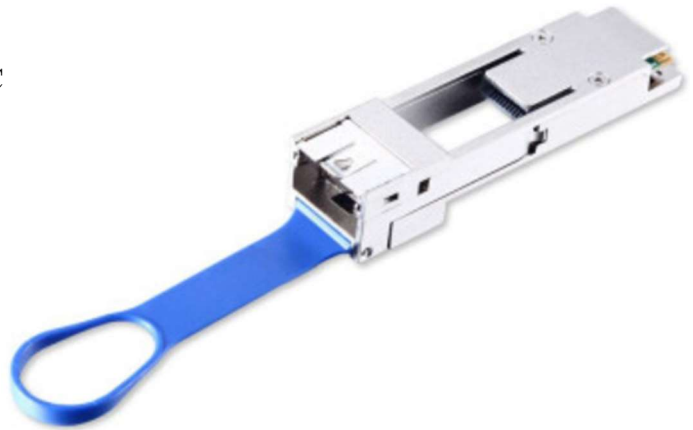

Applications

- Low EMI radiation Switches, servers and routers
- Telecommunication and wireless infrastructure
- Test and measurement equipment
- Networked storage systems
- Data Center networks
- Storage area networks

Product Description

QSFP28 to SFP28 Adapter (QSA) Module offers 25 Gigabit Ethernet connectivity for Quad Small Form-Factor Pluggable (QSFP28)-only platforms. It allows smooth and cost-effective

migration to 100 Gigabit Ethernet by providing an option to use lower-speed Enhanced Small Form-Factor Pluggable (SFP28) modules in empty QSFP28 ports or when the other end of the network is running at lower speeds.

The QSA Module interoperates with all major optical modules and direct attached copper cable vendors. Its design assures minimum loss on the conversion path between the QSFP28 cage and the SFP28 receptacle. The high-speed data channel of the SFP28 receptacle is connected to lane 1 of the QSFP28 connector. The three remaining channels on the QSFP28 connector are not connected. With this adapter, customers have the flexibility to use any SFP28 module or cable to connect to a lower-speed port on the other end of the network. This flexibility allows a cost-effective transition to 100 Gigabit Ethernet by maximizing the use of high-density 100 Gigabit Ethernet QSFP28 platforms. This adapter supports all SFP28 optics and cable reaches. Compatible switch models and SFP28 modules. A list of SFP28 modules that can be plugged into the QSA module is provided in Table 1

The QSA-28 is qualified for 10GbE SFP+ and 1GbE SFP transceivers meeting the Small Form Factor Pluggable (SFP) Transceiver Multi-source Agreement (MSA). The QSA module provides a solution for integrating systems using different vendors' equipment, is vendor agnostic and provides a direct path to the SFP port unit's memory.

Table 1.

Item	Product Name	Product Description
1	SFP28-SR	25GBASE-SR SFP28 Module for Multimode Fiber
2	SFP28-LR	25GBASE-LR SFP28 Module for Single-Mode Fiber
3	SFP28 Passive Copper Cable	SFP28 Copper Cables (1-m to 5-m lengths)
4	SFP28 Active Optical Cable	SFP28 AOC Optical Cables

Recommended Operation Condition

Parameter	Symbol	Min	Max	Unit
Operating Case Temperature	Topc	-20	85	degC
Storage Temperature	Tst	-40	85	degC

Relative Humidity (non-condensation)	RS	-	85	%
Supply Voltage	VCC3	3.15	3.45	V
Power consumption	Pout		0.3	W
Characteristic Impedance	Im	90	110	Ohm
Data Rate		1	25	Gbps

QSFP28 Host board Connector Pinout

Figure 1: MSA compliant Connector

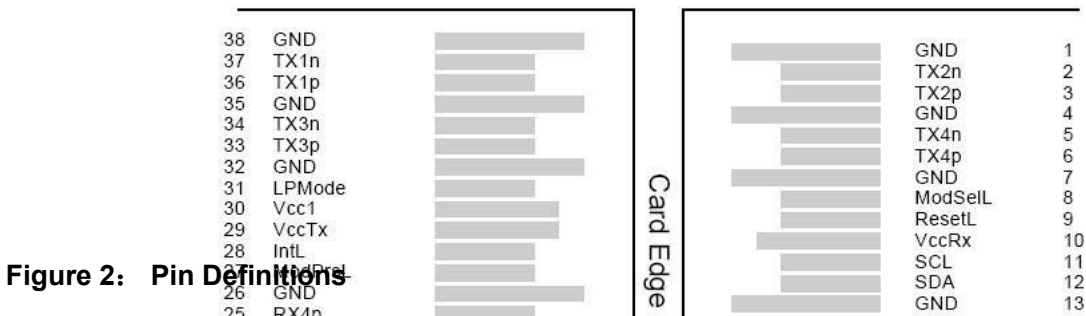

Figure 2: Pin Definitions

Pin	Logic	Symbol	Name/Description	Note
1	22 RX2p 21 RX2n 20 GND	GND	Ground	1
2		Tx2n	Transmitter Inverted Data Input	
3		Tx2p	Transmitter Non-Inverted Data output	
4		GND	Ground	1
5		Tx4n	Transmitter Inverted Data Input	
6		Tx4p	Transmitter Non-Inverted Data output	
7		GND	Ground	1
8		ModSelL	Module Select	
9		ResetL	Module Reset	
10		VccRx	+ 3.3V Power Supply Receiver	2
11		SCL	2-Wire Serial Interface Clock	
12		SDA	2-Wire Serial Interface Data	
13		GND	Ground	
14		Rx3p	Receiver Non-Inverted Data Output	

15	CML-O	Rx3n	Receiver Inverted Data Output	
16		GND	Ground	1
17	CML-O	Rx1p	Receiver Non-Inverted Data Output	
18	CML-O	Rx1n	Receiver Inverted Data Output	
19		GND	Ground	1
20		GND	Ground	1
21	CML-O	Rx2n	Receiver Inverted Data Output	
22	CML-O	Rx2p	Receiver Non-Inverted Data Output	
23		GND	Ground	1
24	CML-O	Rx4n	Receiver Inverted Data Output	1
25	CML-O	Rx4p	Receiver Non-Inverted Data Output	
26		GND	Ground	1
27	LVTTL-O	ModPrsL	Module Present	
28	LVTTL-O	IntL	Interrupt	
29		VccTx	+3.3 V Power Supply transmitter	2
30		Vcc1	+3.3 V Power Supply	2
31	LVTTL-I	LPMODE	Low Power Mode	
32		GND	Ground	1
33	CML-I	Tx3p	Transmitter Non-Inverted Data Input	
34	CML-I	Tx3n	Transmitter Inverted Data Output	
35		GND	Ground	1
36	CML-I	Tx1p	Transmitter Non-Inverted Data Input	
37	CML-I	Tx1n	Transmitter Inverted Data Output	
38		GND	Ground	1

Note:

1. GND is the symbol for signal and supply (power) common for QSFP modules. All are common within the QSFP module and all module voltages are referenced to this potential otherwise noted. Connect these directly to the host board signal common ground plane
2. cc Rx, Vcc1 and Vcc Tx are the receiver and transmitter power suppliers and shall be applied concurrently. Recommended host board power supply filtering is shown below. Vcc Rx, Vcc1 and Vcc Tx may be internally connected within the QSFP transceiver module in any combination. The connector pins are each rated for a maximum current of 500mA.

SFP28 Host board Connector Pinout

Figure 3: MSA compliant Connector

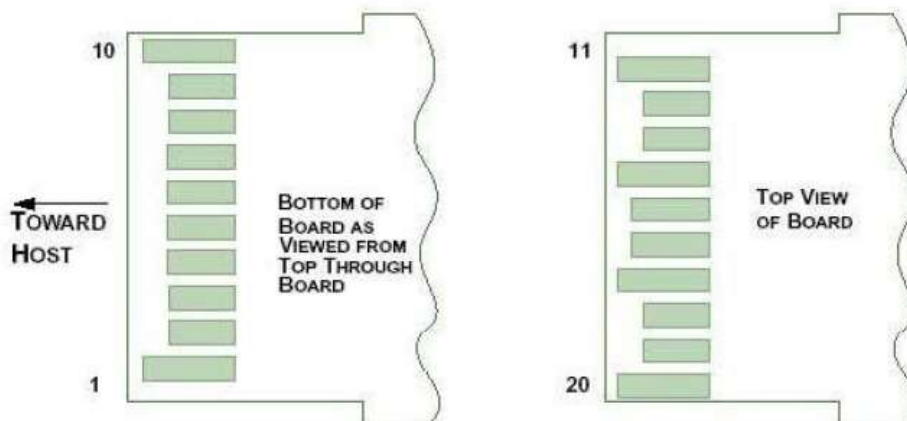

Figure 4: Pin Definitions

Pin	Logic	Symbol	Name/Description	Note
1		VeeT	Module Transmitter Ground	1
2	LVTTL-O	Tx_Fault	Transmitter Fault	2
3	LVTTL-I	Tx_Disable	Transmitter Disable	3
4	LVTTL-I/O	SDA	MOD-DEF2 2-wire serial interface data line	4
5	LVTTL-I/O	SCL	MOD-DEF1 2-wire serial interface clock line	4
6		Mod_Abs	Module Absent	5
7	LVTTL-I	RS0	Rate Select Zero	
8	LVTTL- O	Rx_LOS	Module Receiver Loss of Signal	2
9	LVTTL-I	RS1	Rate Select One	
10		VeeR	Module Receiver Ground	1
11		VeeR	Module Receiver Ground	1
12	CML-O	RD-	Receiver Inverted Data Output	
13	CML-O	RD+	Receiver Non-Inverted Data Output	
14		VeeR	Module Receiver Ground	1
15		VccR	Module Receiver 3.3V Supply	
16		VccT	Module Transmitter 3.3V Supply	
17		VeeT	Module Transmitter Ground	1
18	CML-I	TD+	Transmitter Non-Inverted Data Input	
19	CML-I	TD-	Transmitter Inverted Data Input	
20		VeeT	Module Transmitter Ground	1

Notes:

1. The module signal grounds, VeeR and VeeT, shall be isolated from the module case.
2. This is an open collector/drain output and shall be pulled up with 4.7-10k to Vcc_Host on the host board. Pull ups can be connected to multiple power supplies, however the host board design shall ensure that no module has voltage exceeding module VccT/R + 0.5 V.
3. This is an open collector/drain input and shall be pulled up with 4.7-10k to VccT in the module.
4. See 2-wire electrical specifications.
5. This shall be pulled up with 4.7-10k to Vcc_Host on the host board.

Mechanical Dimensions

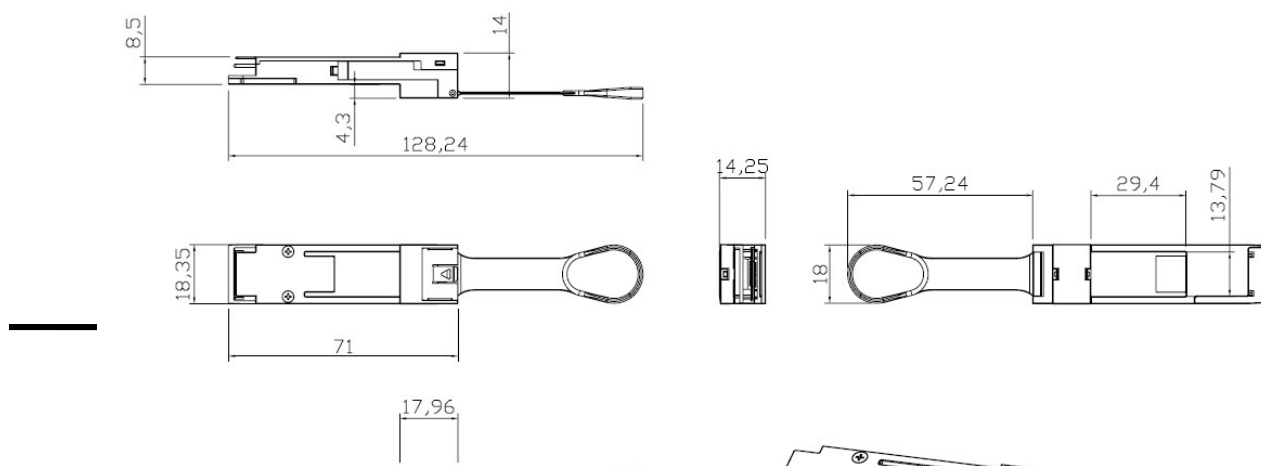

Physical Specifications

Maximum physical dimensions (H x W x D)	13.5 x 18.4 x 78 mm
Weight	Typically, less than 100 g

Ordering Information

Part Number	Description
QSA-28	QSFP28 to SFP28 Adapter (QSA) Module, I2C read port information comes from SFP port module
QSA-28-B	QSFP28 to SFP28 Adapter (QSA) Module, I2C read port information comes from QSA adapter and SFP port module